

unika

J A P A N



Ứng dụng: Lắp máy lạnh - Lắp quạt thông gió, giải nhiệt

unika



DÙNG ĐỤC

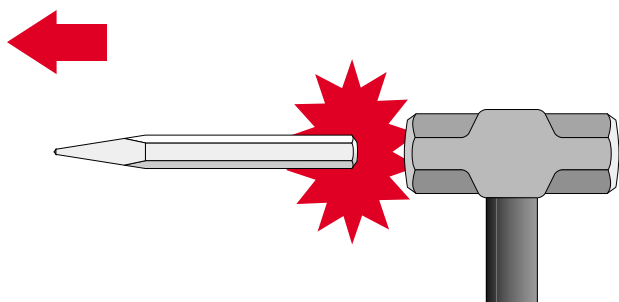

DÙNG MŨI KHOAN RÚT LỖI

Tương thích với máy khoan cầm tay: Đầu kẹp / Đầu gài

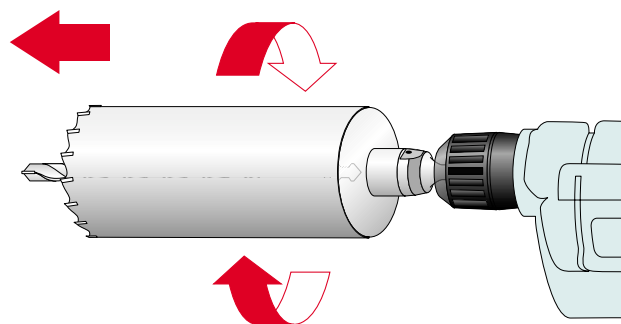

Hoàn Thiện: Không đẹp / dễ gây nứt tường

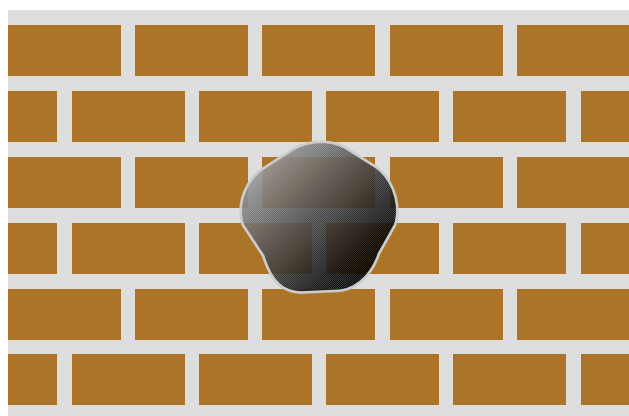

Hoàn Thiện: Đẹp / Ít bụi & không gây nứt tường

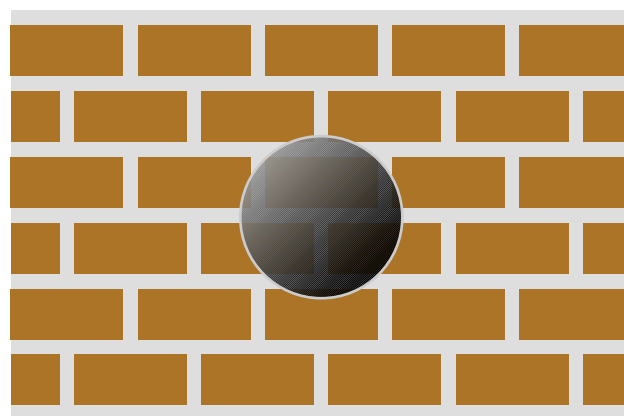

Thời gian thi công: Lâu Thao tác : Mệt nhọc

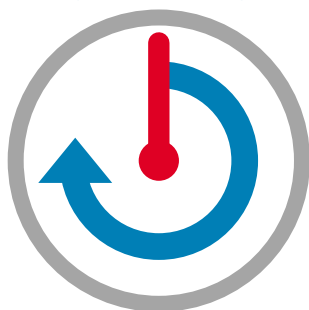

Thời gian thi công: Nhanh Thao tác : Dễ dàng

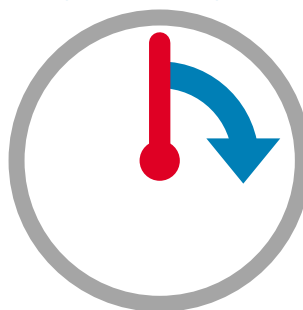

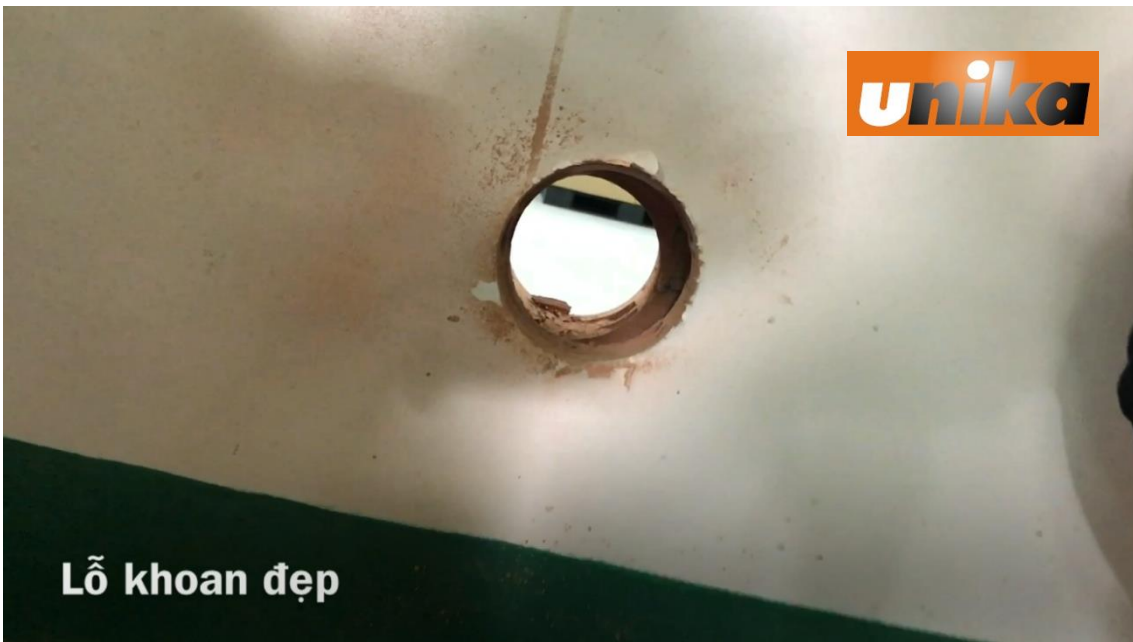

Single-function
Core Drill

E&S RC Type



- Adopts a sharp cutting-edge shape which enables speedy drilling only by rotation.
- Simultaneous pursuit of accuracy and efficiency. Sure and steady drilling is enabled even for fragile work materials.
- Uses "10 mm/13 mm chuck combination shank" allowing most drill chucks.
- SDS shanks are also available at the same price.

Effective Length Please refer to the spec table.

Applicable Electric Tool Electric Drill / Percussion Drill (rotating mode)

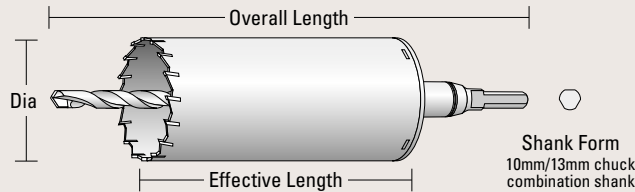

PVC	PLASTERBOARD	SLATE	BLOCK/BRICK
MORTAR	JAPANESE WALL	ROOF TILE	PORCELAIN TILE
PLASTIC	PORCELAIN PIPE	EXTERIOR PANELS	

CORE DRILLS

Rotation



- Equipped with "drilling swarf discharge holes" in consideration of debris. Drilling swarf discharge holes for drills with a diameter of 22 - 38 mm positioned on the body side surface.
- "10mm/13mm chuck combination shank" allows for most drill chucks.

Cutting edge shape

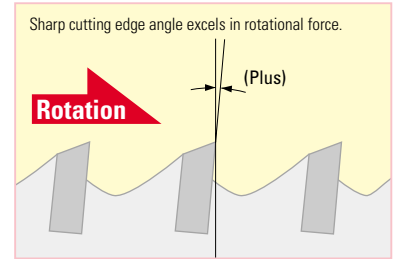

ES-R (Straight-Shank)				
	Code	Diameter (mm)	Overall Length (mm)	Effective Length (mm)
	ES-R22ST	22	235	135
	ES-R25ST	25	270	150
○	ES-R29ST	29		
△	ES-R32ST	32		
	ES-R35ST	35		
	ES-R38ST	38		
	ES-R40ST	40	269	135
	ES-R45ST	45		
○	ES-R50ST	50		
△	ES-R55ST	55		
	ES-R60ST	60		
◎	ES-R65ST	65		
	ES-R70ST	70		
	ES-R75ST	75		
◎	ES-R80ST	80		
	ES-R85ST	85		
○	ES-R90ST	90		
	ES-R95ST	95	269	135
	ES-R100ST	100		
	ES-R105ST	105		
	ES-R110ST	110		
◎	ES-R120ST	120		
△	ES-R130ST	130		
○	ES-R150ST	150		
	ES-R160ST	160		
◎	ES-R170ST	170		
	ES-R200ST	200		
△	ES-R220ST	220		

ES-R (SDS-Shank)				
	Code	Diameter (mm)	Overall Length (mm)	Effective Length (mm)
	ES-R25SDS	25	283	150
	ES-R29SDS	29		
	ES-R32SDS	32		
	ES-R35SDS	35		
	ES-R38SDS	38		
	ES-R40SDS	40	282	135
	ES-R45SDS	45		
○	ES-R50SDS	50		
	ES-R55SDS	55		
	ES-R60SDS	60		
○	ES-R65SDS	65		
	ES-R70SDS	70		
	ES-R75SDS	75		
△	ES-R80SDS	80		
	ES-R85SDS	85		
	ES-R90SDS	90		
	ES-R95SDS	95	282	135
△	ES-R100SDS	100		
	ES-R105SDS	105		
△	ES-R110SDS	110		
△	ES-R120SDS	120		
	ES-R130SDS	130		
	ES-R150SDS	150		
	ES-R160SDS	160		
△	ES-R170SDS	170		
	ES-R200SDS	200		
	ES-R220SDS	220		

Single-function
Core Drill

E&S DC Type



- Capable of drilling reinforced concrete (cutting up to triple-reinforcement) by dry process without using water.
- Center pin positions only to reduce vibration and noise.
- Uses "10 mm/13 mm chuck combination shank" allowing most drill chucks.
- SDS shanks are also available at the same price.

*Use water for cooling the cutting edge when drilling ceramic tiles and stone.

Effective Length Please refer to the spec table.

Applicable Electric Tool Electric Drill / Percussion Drill (rotating mode)

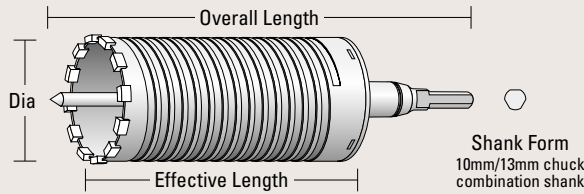

Dry Diamond



REINFORCED CONCRETE **HARD EXTERIOR PANEL**

Resin-based ARTIFICIAL MARBLE **MORTAR** EXTRUDED CEMENT PANEL

SOFT EXTERIOR PANEL **BLOCK / BRICK** * CERAMIC TILE

CORE DRILLS

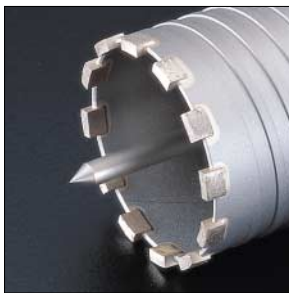

Cutting edge shape

Using diamond particles, drilling is performed through grinding the worked on material.

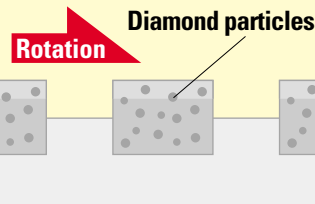

ES-D (Straight-Shank)

	Code	Diameter (mm)	Overall Length (mm)	Effective Length (mm)	
△	ES-D25ST	25	253	150	
△	ES-D29ST	29			
○	ES-D32ST	32			
○	ES-D35ST	35			
○	ES-D38ST	38			
	ES-D40ST	40	252	135	
	ES-D45ST	45			
○	ES-D50ST	50			
	ES-D55ST	55			
	ES-D60ST	60			
◎	ES-D65ST	65			
△	ES-D70ST	70			
	ES-D75ST	75			
	ES-D80ST	80			
	ES-D85ST	85			
	ES-D90ST	90			
	ES-D95ST	95	252	135	
	ES-D100ST	100			
	ES-D105ST	105			
	ES-D110ST	110			
	ES-D120ST	120			
	ES-D130ST	130			
	ES-D150ST	150			
	ES-D160ST	160			
	ES-D170ST	170			

ES-D (SDS-Shank)

	Code	Diameter (mm)	Overall Length (mm)	Effective Length (mm)	
△	ES-D25SDS	25	266	150	
○	ES-D29SDS	29			
◎	ES-D32SDS	32			
○	ES-D35SDS	35			
◎	ES-D38SDS	38			
△	ES-D40SDS	40	265	135	
	ES-D45SDS	45			
◎	ES-D50SDS	50			
	ES-D55SDS	55			
△	ES-D60SDS	60			
◎	ES-D65SDS	65			
○	ES-D70SDS	70			
	ES-D75SDS	75			
△	ES-D80SDS	80			
	ES-D85SDS	85			
	ES-D90SDS	90			
	ES-D95SDS	95	265	135	
	ES-D100SDS	100			
	ES-D105SDS	105			
	ES-D110SDS	110			
	ES-D120SDS	120			
	ES-D130SDS	130			
	ES-D150SDS	150			
△	ES-D160SDS	160			
	ES-D170SDS	170			

ES-DH For Hume Pipe (SDS-Shank)

Build to order

	Code	Diameter (mm)	Overall Length (mm)	Effective Length (mm)	
	ES-DH150SDS	150	265	135	
	ES-DH170SDS	170			
	ES-DH200SDS	200			
	ES-DH220SDS	220			

Handling Method

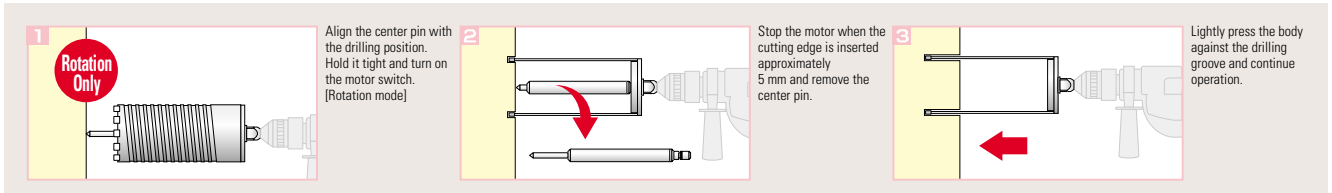

* ドレス (目立て・目出し) 作業についてはP.12をご覧ください。